

# Design of Shunt Active Power Filter to eliminate harmonics generated by CFL

<sup>1</sup>Bibha Rani Singh, <sup>2</sup>Dr. Ranjana Singh

Dept. of Electrical Engineering, Jabalpur engineering college, Jabalpur, India

---

**Abstract:** The use of non-linear loads; such as TV sets and computer, microwave ovens, multiple low power diode rectifier, fluorescent lamps and electric drives, draw very distorted currents. These non-linear loads lead to generation of current/voltage harmonics and draw reactive power. This paper presents the three-phase shunt active power filter (SAPF) to compensate harmonics generated by non-linear load (compact fluorescent lamp). The instantaneous active and reactive power theory (called p-q theory) is used to design the control of SAPF. The harmonic distortion and the active filter control scheme have been verified by MATLAB simulation.

**Keywords:** Non-linear load (CFL), shunt active power filter, harmonic distortion, P-Q theory, hysteresis control.

---

## 1. INTRODUCTION

In recent years many power electronics convertors utilizing switching devices have been widely used in industrial as well as in domestic applications. It desire to draw purely sinusoidal currents from the distribution network, but this is no longer the case with this new generation of receivers that take advantage of all the recent advances and improvements in power electronics. These power electronics systems such as high power diode/thyristor rectifiers, arc furnaces, cyclo-convertors, and variable speed drives offer highly non-linear characteristics. Some of the small power domestic electrical appliances like TV sets and computers, microwave ovens, battery chargers, electronic ballasts, variable frequency drives and switching mode power supplies also draw very distorted currents. These non-linear loads lead to generation of current/voltage harmonics and draw reactive power and becoming troublesome problems in ac power lines. [1]

Power system harmonics are integer multiples of the fundamental power system frequency. High level of power system harmonics can create voltage distortion and power quality problems. [2-4] Harmonics in power systems result in increased heating in the equipment and conductors, misfiring in variable speed drives, torque pulsation in motors, low system efficiency, and poor power factor. [5] It also causes disturbance to other consumers and interference in nearby communication networks. The effect of this non-linearity could become sizeable over the next few years. Hence it is very important to overcome these undesirable features.

Traditionally, passive filters have been used to reduce line current harmonics, to compensate the reactive power and improve the power factor. However, passive filters are Bulky, load dependent and they only filter the frequencies they were previously tuned for; their operation cannot be limited to a certain load; resonances can occur because of the interaction between the passive filters and other loads, with unpredictable results. In order to solve these problems, Active power filters APFs have been considered as a possible solution for reducing current harmonics and also minimizing of power loses while transmission of energy from source to load [6]

Active filters avoid the disadvantages of passive filters by using a switch mode power electronic converter to supply harmonic currents equal to those in the load currents. Different active power filters topologies have been presented in the technical literature [7-11]. Moreover, the active power filter can also compensate the load power factor. In this way, the power distribution system sees the non-linear load and the active power filter as an ideal resistor. [12] The shunt active power filter based on the current-controlled voltage source type PWM converter has proved to be effective even when the load is highly non-linear [13].

The control strategy applied in this paper is based on the instantaneous power in the  $\alpha$ - $\beta$ -0 reference frame (p-q theory), proposed by Akagi et al. [14-15]. In literature, several works can be found on control strategies for active power filters based on instantaneous power theory [16].

This paper presents simulation results that evaluate the performance of the shunt active power filter with non-linear Load CFLs. The instantaneous Reactive Power theory of the active filter will be analysed and discussed for CFLs load. The presented system is able to compensating current harmonics, the total harmonic distortion THD is calculated for load before and after filtering.

## 2. COMPACT FLUORESCENT LAMP

A Compact fluorescent lamps also called compact fluorescent light, energy saving light, and compact fluorescent tube, is a fluorescent lamp design to replace an incandescent lamp; some types fixed into light fixture formerly used for incandescent lamps. The lamps use a tube which is curved or folded to fit into the space of an incandescent bulb, and compact electronic ballast in the base of the lamp.

Compared to general-service incandescent lamps giving the same amount of visible light, CFLs use one-fifth to one-third the electric power, and last eight to fifteen times longer. A CFL has a higher purchase price than an incandescent lamp, but can save over five times purchase price in electricity costs over the lamp's lifetime. [17] The life span of incandescent lamp is approx. 2000 hours while the life span of CFL is between 6000 hours to 15000 hours. [18]

## 3. MODEL DESCRIPTION

The CFL ballasts have to be designed to ensure reliable and safe feeding of the curved fluorescent tube with necessary performance characteristics in all operating states. Figure-1 shows the block diagram of electronic ballast for CFL.

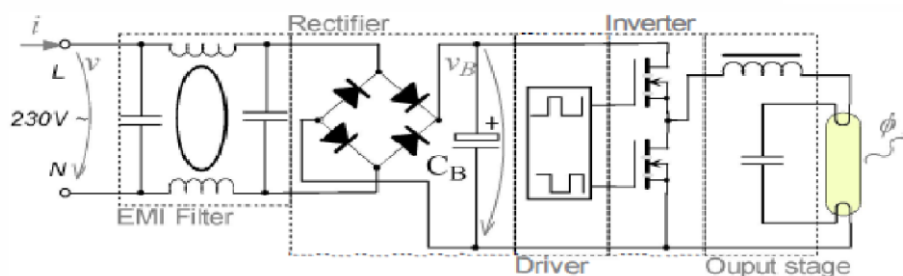


Figure-1 Block diagram of electronic ballast for CFL

The basic assumption of the proposed model is that it is possible to represent the CFL electrical circuit behaviour by means of a simple rectifier, with filter capacitor, supplying a resistive load. Thus, the resistor exhibits an equivalent lamp substituting the inverter with resonant network and high frequency discharge.

Figure-2 reports the simplified model of the CFL designed with a view to involve as few parameters as possible, as it has been implemented in SimPowerSystem under Matlab. The model is composed by three sections: the supply, the converter and the lamp models.

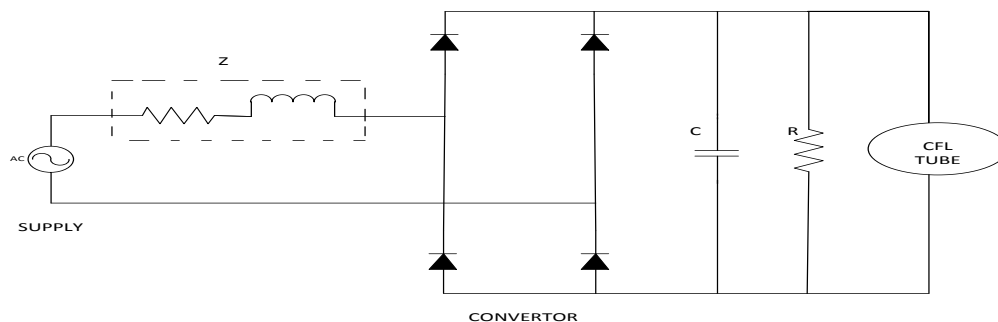


Figure-2 Simplified model of CFL

The supply model is constituted by the series of the fundamental and interharmonic voltage generators followed by the network equivalent impedance. The converter model is constituted by a three phase full-wave rectifier feeding the parallel connection of the smoothing capacitor and of the resistor representing the equivalent lamp.

#### 4. SHUNT ACTIVE POWER FILTER

The shunt active power filter acts as a current generator that compensated the load current, in such a way that the source current drained from the network will become sinusoidal and in phase with the voltage. Fig. 3 shows the basic compensation principle of the shunt active power filter. It is controlled to draw or supply a compensating current  $I_f$  from or to the utility, so that cancels current harmonics on the source side. So, the current is the result of summing the load current  $I_L$  and the opposite filter current  $I_f$ :

$$I_s = I_L - I_f \quad (1)$$

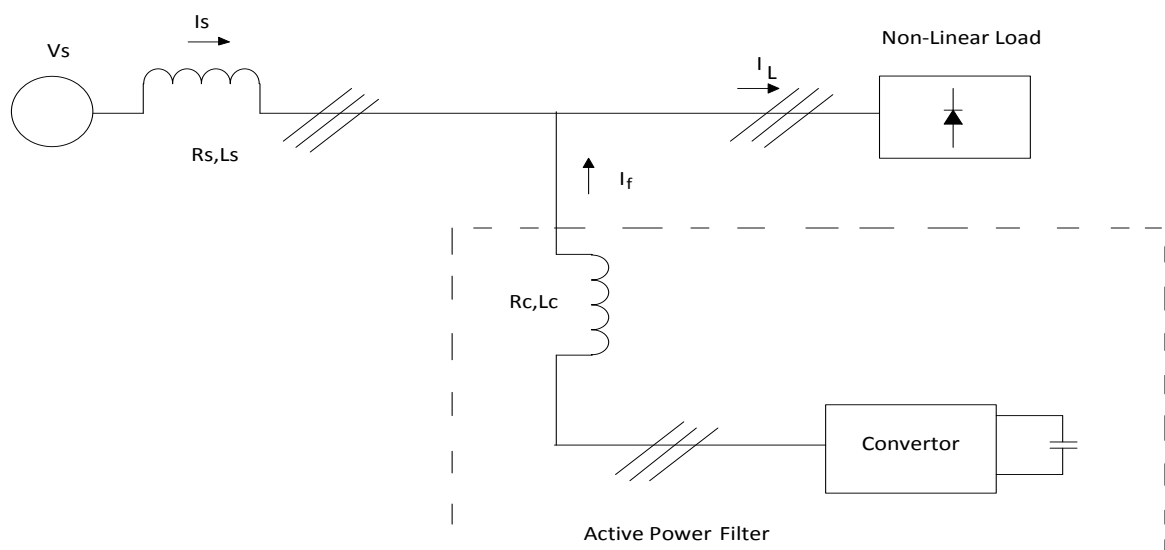


Fig.-3 Basic compensation principle of SAPF

#### 5. CONTROL STRATEGY

Control method is the key factor for successful implementation of Shunt active power filter. Figure 4 shows a block diagram of SAPF. In this paper SAPF is controlled using instantaneous reactive power theory (IRP). Instantaneous reactive power theory, developed by Akagi et al [14], is used to control the shunt active power filter SAPF. This theory, known as p-q Theory, consists of a Clarke transformation of three-phase voltages and load currents from the a-b-c coordinates to the  $\alpha$ - $\beta$ -0 coordinates:

$$\begin{bmatrix} V_{s\alpha} \\ V_{s\beta} \end{bmatrix} = \sqrt{(2/3)} \begin{bmatrix} 1 & -1/2 & -1/2 \\ 0 & \sqrt{3}/2 & -\sqrt{3}/2 \end{bmatrix} \begin{bmatrix} V_{sa} \\ V_{sb} \\ V_{sc} \end{bmatrix} \quad (2)$$

$$\begin{bmatrix} i_{L\alpha} \\ i_{L\beta} \end{bmatrix} = \sqrt{(2/3)} \begin{bmatrix} 1 & -1/2 & -1/2 \\ 0 & \sqrt{3}/2 & -\sqrt{3}/2 \end{bmatrix} \begin{bmatrix} i_{La} \\ i_{Lb} \\ i_{Lc} \end{bmatrix} \quad (3)$$

One advantage of applying the  $\alpha$ - $\beta$ -0 transformation is the separation of zero-sequence components into the zero sequence axis. Naturally, the  $\alpha$  and  $\beta$  axis do not have any contribution from zero-sequence components. If the three phase system has not neutral conductor, no zero sequence current components are present and can be eliminated in the above equations

[19], simplifying them. In this situation the p-q instantaneous power components are calculated by using load currents and source voltages as:

$$p = V\alpha \cdot iL\alpha + V\beta \cdot iL\beta \tag{4}$$

$$q = V\alpha \cdot iL\beta - V\beta \cdot iL\alpha \tag{5}$$

Matrix form of the above equations can be given as eq. (6),

$$\begin{bmatrix} p \\ q \end{bmatrix} = \begin{bmatrix} Vs\alpha & Vs\beta \\ -Vs\beta & Vs\alpha \end{bmatrix} \begin{bmatrix} iL\alpha \\ iL\beta \end{bmatrix} \tag{6}$$

Instantaneous real and imaginary powers include AC and DC components. Normally only the average value of the instantaneous power is desirable and the other power components can be compensated using a parallel active filter.

Hence, the load currents components can be obtained from direct and alternative powers as follow:

$$\begin{bmatrix} iL\alpha \\ iL\beta \end{bmatrix} = \frac{1}{Vs\alpha^2 + Vs\beta^2} \begin{bmatrix} Vs\alpha & -Vs\beta \\ Vs\beta & Vs\alpha \end{bmatrix} \begin{bmatrix} p \\ q \end{bmatrix} \tag{7}$$

In general, when the load is nonlinear the real and imaginary powers can be divided in average components  $\bar{p}$  and  $\bar{q}$  and oscillating components  $\tilde{p}$  and  $\tilde{q}$ , as shown below.

$$\begin{bmatrix} iL\alpha \\ iL\beta \end{bmatrix} = \frac{1}{\Delta} \begin{bmatrix} Vs\alpha & -Vs\beta \\ Vs\beta & Vs\alpha \end{bmatrix} \begin{bmatrix} \bar{p} \\ \bar{q} \end{bmatrix} + \frac{1}{\Delta} \begin{bmatrix} Vs\alpha & -Vs\beta \\ Vs\beta & Vs\alpha \end{bmatrix} \begin{bmatrix} 0 \\ 0 \end{bmatrix} + \frac{1}{\Delta} \begin{bmatrix} Vs\alpha & -Vs\beta \\ Vs\beta & Vs\alpha \end{bmatrix} \begin{bmatrix} \tilde{p} \\ \tilde{q} \end{bmatrix} \tag{8}$$

Active current                  reactive current                  harmonics current

In order to calculate the reference currents that the active filter should inject, it is necessary to separate the desired average power components  $\bar{p}$  and  $\bar{q}$  from the undesired oscillating harmonic power components  $\tilde{p}$  and  $\tilde{q}$ . This is obtained by a low pass filter applied to P and q. Harmonic components of  $iL\alpha$  and  $iL\beta$  are the reference currents of parallel active power filter. And then they are transformed to three-phase system by:

$$\begin{bmatrix} i_{fa}^* \\ i_{fb}^* \\ i_{fc}^* \end{bmatrix} = \sqrt{2/3} \begin{bmatrix} 1 & 0 \\ -\frac{1}{2} & \frac{\sqrt{3}}{2} \\ -\frac{1}{2} & -\frac{\sqrt{3}}{2} \end{bmatrix} \begin{bmatrix} i_{f\alpha}^* \\ i_{f\beta}^* \end{bmatrix} \tag{9}$$

The inputs of the parallel active filter controller are the network voltages, load currents and real filter currents as shown in the figure 4.

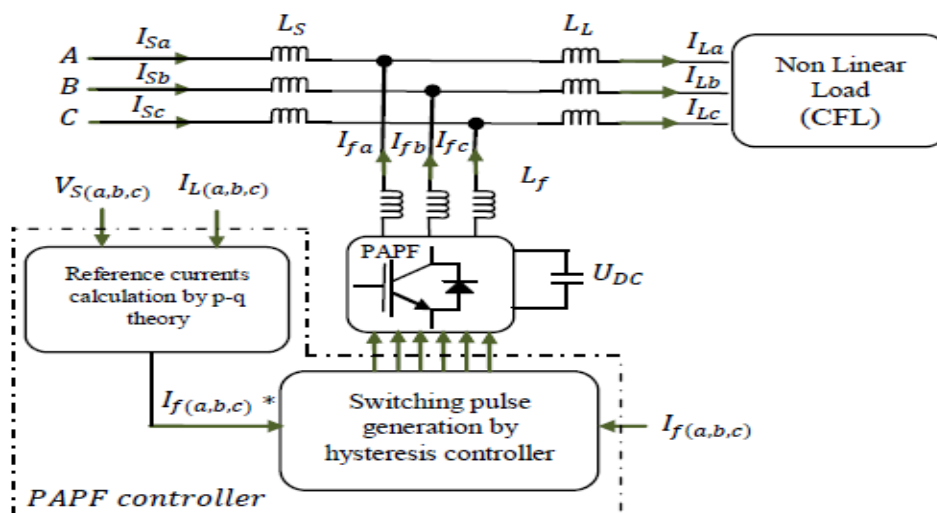


Fig. 4 Block diagram of SAPF [Ref.]

The switching signals used in shunt active power filter control algorithm are generated by comparing filter reference currents and actual filter currents and using hysteresis band current control algorithm. The hysteresis band is used to control the supply current and determine the switching signals for inverters gates. When the supply current exceeds the upper band, the comparators generate control signals in such a way to decrease the supply current and keep it between the bands [20].

The hysteresis band current control technique has proven to be most suitable for applications of current controlled voltage source inverters. The hysteresis band current control is characterized by unconditioned stability, very fast response, and good accuracy [15]. The hysteresis band current control scheme is composed of a hysteresis around the reference filter current. The hysteresis band current controller decides the switching pattern of active power filter. The switching logic of transistors is given as follows:

$$i_{fa} < i_{fa}^* - \Delta i_f ; T_a \text{ on and } T_a' \text{ off}$$

$$i_{fa} > i_{fa}^* + \Delta i_f ; T_a \text{ off and } T_a' \text{ on} \quad (10)$$

The switching functions of transistors  $T_b$ ,  $T_b'$  and  $T_c$ ,  $T_c'$  for phases B and C are determined similarly. Here  $\Delta i_f$  is the band width of hysteresis band.

## 6. SIMULATION RESULTS OF SAPF

The performances of the shunt active power filter are simulated using MATLAB software. Simulink and SimPower Systems block sets are used for implementing the global system (CFL and SAPF). Figure 5 shows the Simulink block of non linear load (CFL) with SAPF.

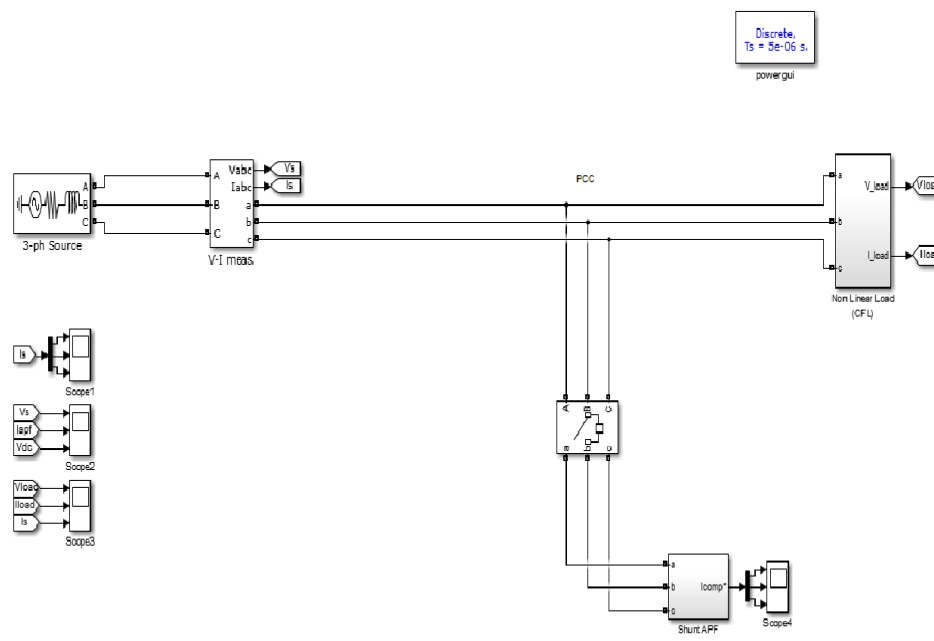
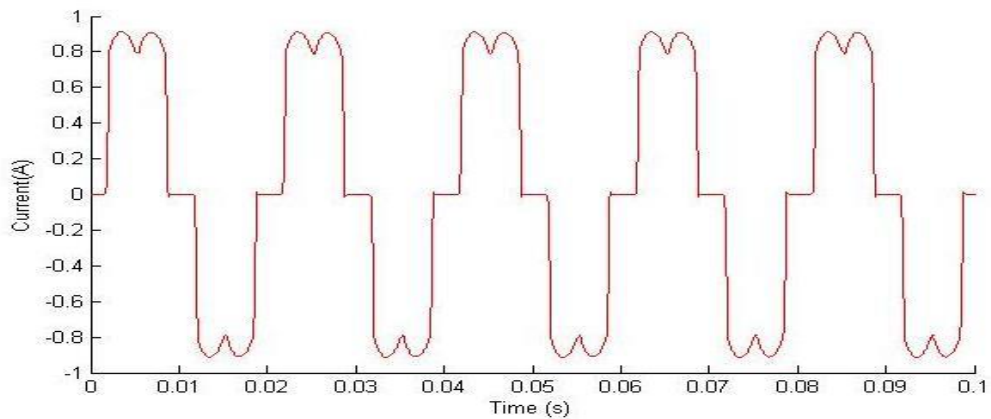
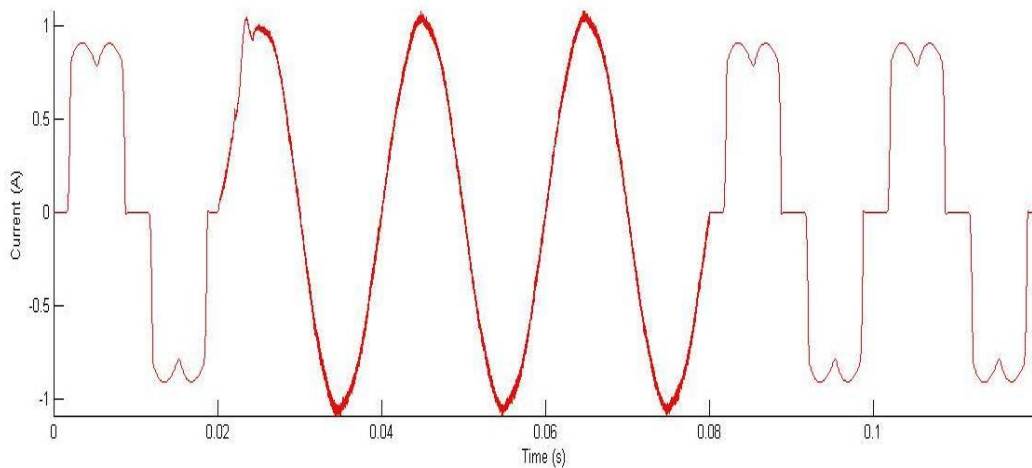


Fig. 5 Simulink model of CFL with SAPF

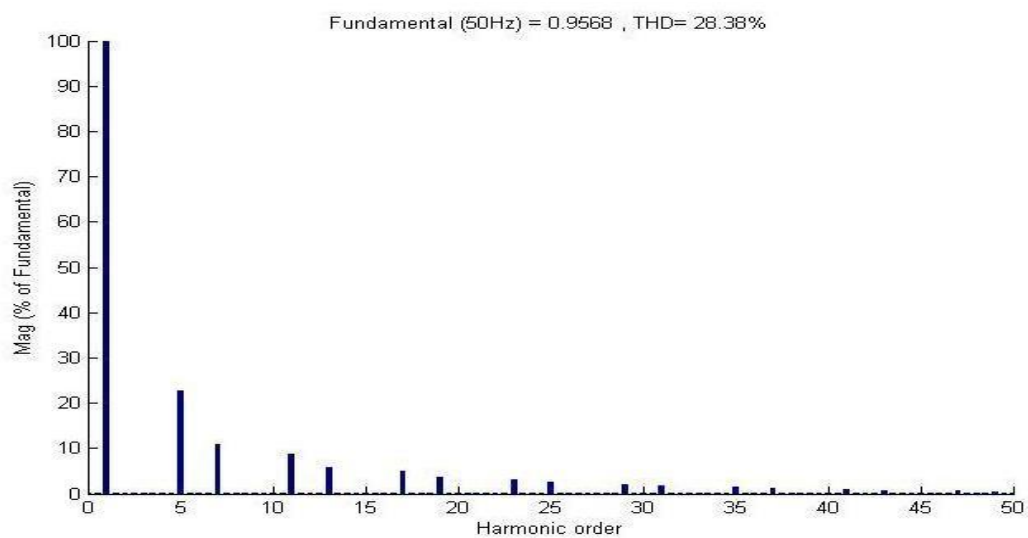
Simulation results are given here for CFL load. Fig.6 shows the load current before and after shunt active power filter connection and fig. 7 shows the source current before and after SAPF connection and disconnection. Fig. 8 shows the FFT analysis of load and fig. 9 shows the FFT analysis of source current. It may be noted that, before filter connection, the source current waveform is non-sinusoidal because of which its THD is as 28.38% and its fundamental value is 0.9568 A. However after filter connection the source current has a THD is 2.49% and its fundamental value is 1.041 A. The fundamental value remains approximately the same when the filter is connected which prove that the filter injects only the harmonic currents and the grid injects the fundamental component of the load current.



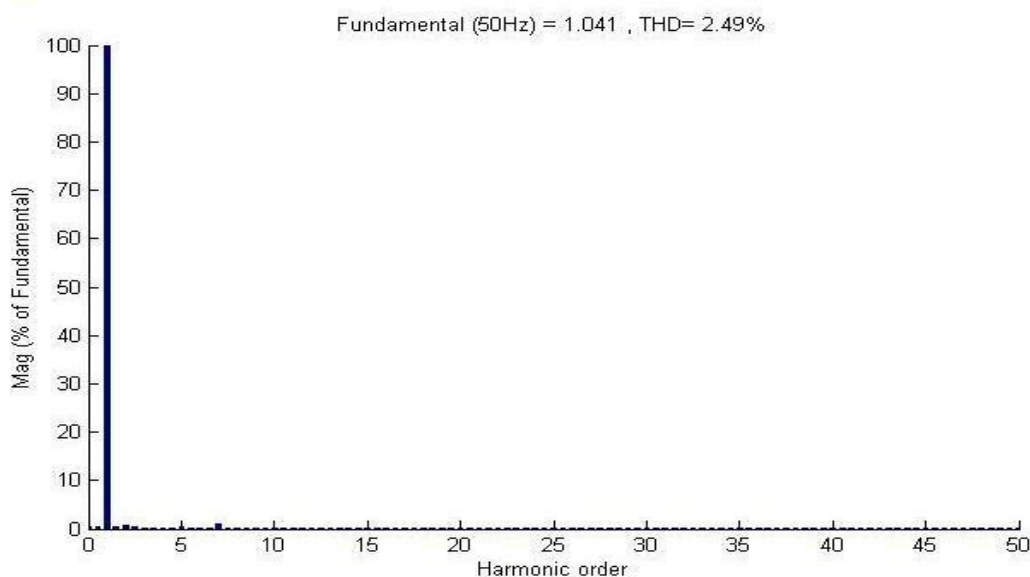
**Fig.6 Load current before and after shunt active power filter connection**



**Fig. 7 source current before and after SAPF connection and disconnection**

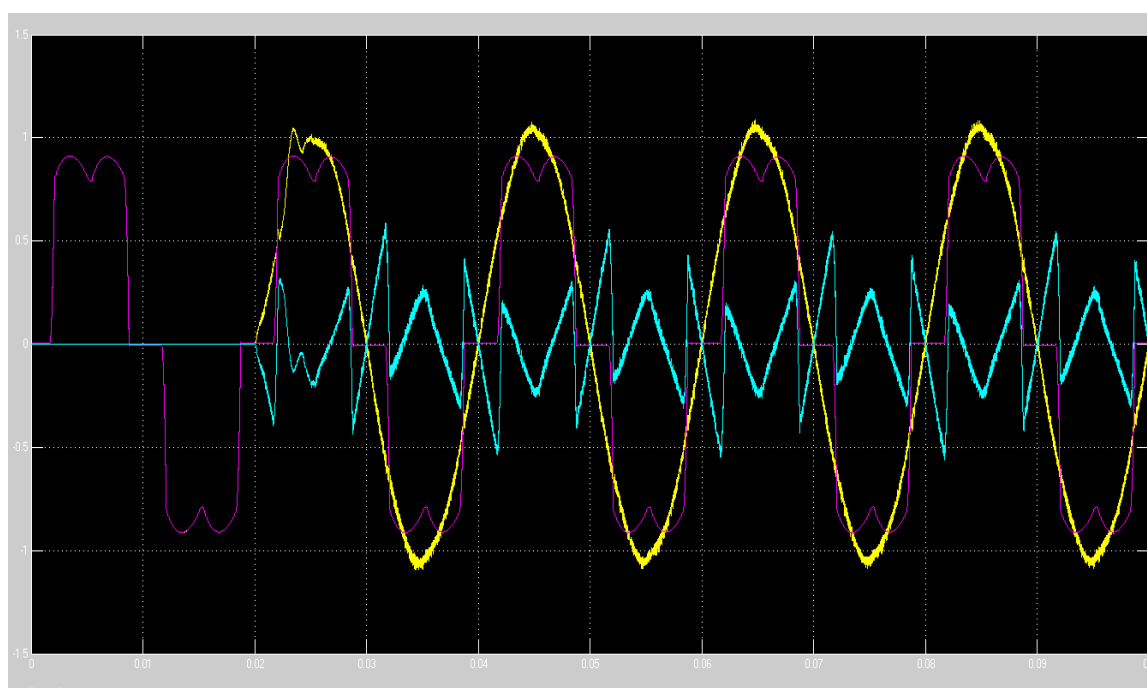


**Fig. 8 FFT analysis of load**



**Fig. 9 FFT analysis of source after compensation**

Fig. 10 shows the schematic digram of source, load and filter current before and after SAPF connection (yellow: source current, blue: filter current, purple: load current)



**Fig. 10 the schematic digram of source current, load current and filter current before and after shunt active power filter connection**

## 7. CONCLUSION

The key factor for successful performance of SAPF is reference current. The reference current using instantaneous reactive power theory is presented in this paper. Reference current is further used for generation of pulses. SAPF helps in reducing total harmonic distortion and maintain it to acceptable level. SAPF helps in improving power quality. The simulation results using MATLAB/simulink verifies that. The advantage of p-q theory is that it implements less mathematical calculations. p-q theory can effectively and efficiently be used to control shunt active power filters.

## REFERENCES

- [1] W.K. Chang, W. Grady., “Minimizing harmonic voltage distortion with multiple current-constrained active power line conditioners” IEEE Trans. Power Delivery 12 (2),1997, pp.837-/843.
- [2] Yong.Z and al “Optimal planning of harmonic filters on distribution systems by chance constrained programming”. Electric Power Systems Research 68 ,2004, pp. 149-156.
- [3] T.T. Chang, H.C. Chang, “An efficient approach for reducing harmonic voltage distortion in distribution systems with active power line conditioners”, IEEE Trans. Power Delivery 15 (3), 2000, pp. 990-995.
- [4] Abdel Aziz, M. M., Abou El-Zahab, E. E.-D., Zobaa, A. F., & Khorshied, D. M “Passive harmonic filters design using Fortran feasible sequential quadratic programming”. Electric Power Systems Research, 77(5-6), 2007, pp. 540–547.
- [5] M. Liserre, F. Blaabjerg, S. Hansen, Design and control of an LCLfilter- based three-phase active rectifiers, IEEE Transactions on Industry Applications 41, 2005, pp. 1281–1291. M.A.E. Alali, S. Saadate, Y.A. Chapuis, F. Braun.,” Control and analysis of series and shunt active filters with SABER”. IPEC 2000, Tokyo, Japan, pp. 1467-1472.
- [6] M. Aredes, K. Heuman and E. Watanabe, “An Universal Active Power Line Conditioner”, IEEE Trans. on Power Delivery, vol. 13, no 2, pp.545-551, April 1998.
- [7] L. Morán, L. Fernández, J. Dixon, R. Wallace, “A Simple and Low Cost Control Strategy for Active Power Filters Connected in Cascade”, IEEE Trans. on Industrial Electronics, vol. 44, no. 5, pp. 621-629, Oct. 1997.
- [8] B. Singh, K. Al-Haddad, and A. Chandra, “A review of active filters for power quality improvement.” IEEE Transactions on Industrial Electronics, vol. 46, no. 5, pp. 1-12, October 1999.
- [9] Eswaran Chandra Sekaran, Ponna Nadar Anbalagan, Chelliah Palanisamy, “ANALYSIS AND SIMULATION OF A NEWSHUNT ACTIVE POWER FILTER USING CASCADED MULTILEVEL INVERTER” Journal of ELECTRICAL ENGINEERING, VOL. 58, NO. 5, 2007, 241–249
- [10] PROF. DR. EMİN TACER, Akram Qashou and Nezihe yildiran, “Shunt Active Power Filters Based On Diode Clamped Multilevel Inverter and Hysteresis Band Current Controller” Innovative Systems Design and Engineering [www.iiste.org](http://www.iiste.org) ISSN 2222-1727 (Paper) ISSN 2222-2871 (Online) Vol.4, No.14, 2013
- [11] Fraidoon Mazda “Power Electronics Handbook“, Third edition, Anthony Rowe Ltd, Eastbourne, 1997.
- [12] H. Akagi, “Trends in active power line conditioners,” IEEE Transactions on power electronics, vol. 9, no. 3, pp. 263-268, 1994
- [13] AKAGI, H.—KANAZAWA, Y.—NABAE, A. : Generalized Theory of the Instantaneous Reactive Power in Three-Phase Circuits, IPEC’83 – Int. Power Electronics Conf., Tokyo, Japan, 1983, pp. 1375–1386.
- [14] Nilesh M. Chamat, Vikas S. Bhandare, Snehal Jamadade, Prof. S. P. Diwan, “Instantaneous Reactive Power Theory for Real Time Control of Three-Phase Shunt Active Power Filter (SAPF)” 2014 International Conference on Circuit, Power and Computing Technologies [ICCPCT].
- [15] Ricardo Pregitzer, J. C. Costa, Júlio S. Martins, and João L. Afonso, “Simulation and Implementation Results of a 3 Phase 4 Wire Shunt Active Power Filter”, Proceedings (CD-ROM) ICHQP’2006 - International Conference on Harmonics and Quality of Power, 1-5 Oct. 2006, Cascais, Portugal.
- [16] “Compact fluorescent light bulbs” Energy star. Retrieved 2010-09-30.
- [17] [Online] [www.diffen.com/difference/Fluorescent-Bulb-Vs-Incandescent-bulb](http://www.diffen.com/difference/Fluorescent-Bulb-Vs-Incandescent-bulb)
- [18] Clarke, E. “Circuit Analysis of A-C Power Systems“, Vol. I. Symmetrical and Related Components, New York: John Wiley and Sons, Inc, 1943.
- [19] Mohamed R. Amer, Osama A. Mahgoub, Sherif A. Zaid “New Hysteresis Control Method for Three Phase Shunt Active Power Filter” Proceedings of the International MultiConference of Engineers and Computer Scientists 2011 Vol II, IMECS 2011, March 16 - 18, 2011, Hong Kong.